

JP30 ELECTRIC TOWBARLESS TUG CRITICAL DIMENSIONS

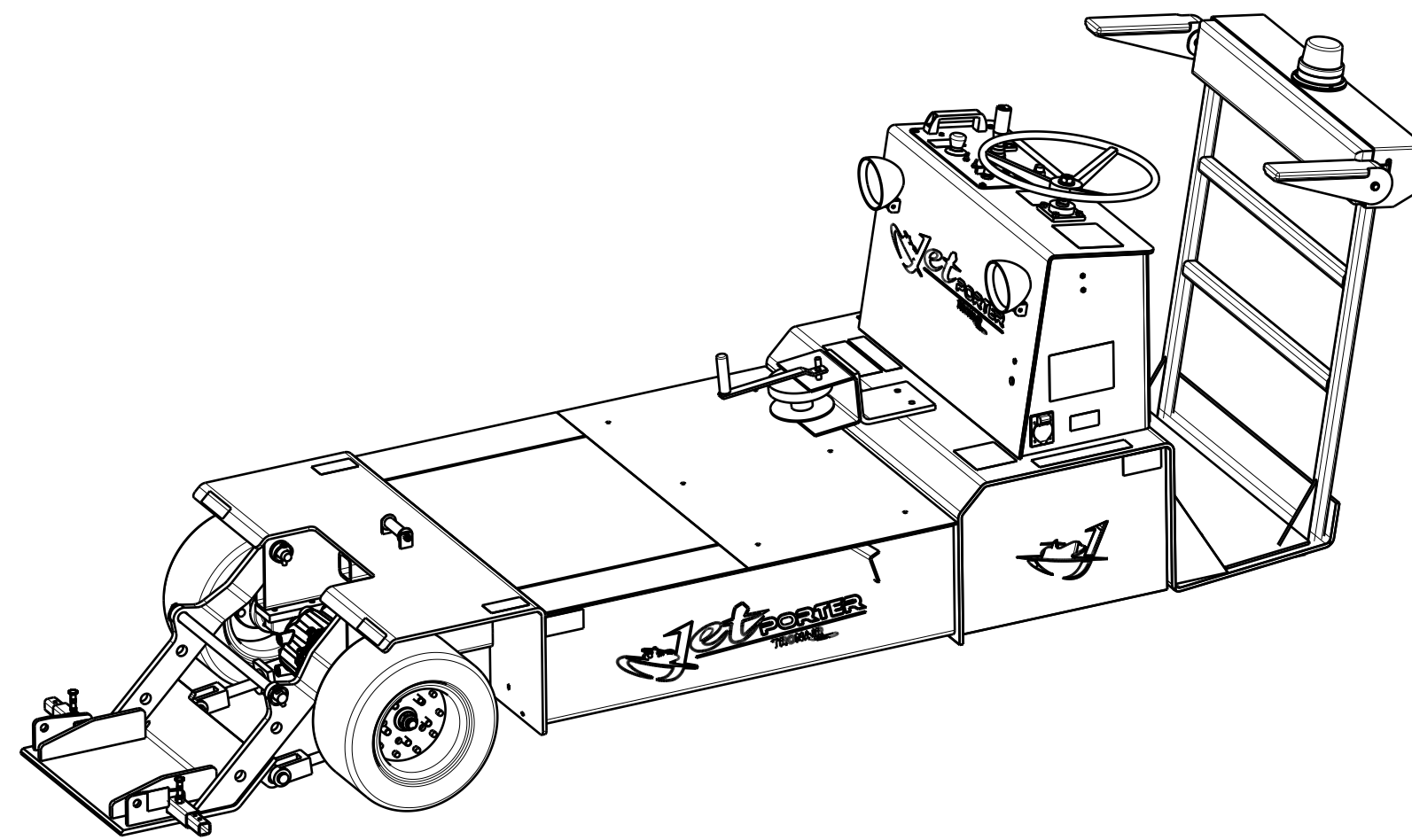

GENERAL DESCRIPTION:

MAX TOWING CAPACITY:	30,000 LBS (13608 KG)
OVERALL HEIGHT:	49 7/16" (125.6 CM)
OVERALL WIDTH:	40" (101.6 CM)
OVERALL LENGTH:	135" (342.9 CM)
WEIGHT:	2,400 LBS (1089 KG) W/BATT 1,870 LBS (848 KG) WO/BATT
FINISH:	POWDER COAT TRONAIR BLUE
MAX CRADEL CAPACITY:	3,000 LBS (1361 KG)
MAX CRADEL TIRE WIDTH:	19" (48.3 CM)
STEERING TIRES:	(2) 4.00 X 8
DRIVE TIRES:	(2) 16 X 7.5
GROUND CLEARANCE:	3 5/16" (8.4 CM)
DECK HEIGHT:	18" (45.7 CM)
CRADEL DEPTH:	15 5/8" (39.7 CM)
CRADEL WIDTH:	19" (48.3 CM)
CRADEL LIFT HEIGHT:	6" (15.2 CM)

POWER

BATTERY TYPE:	EIGHT – 6 VOLT DEEP CYCLE
CHARGE TIME FULL DISCHARGE:	8 HOUR AVERAGE
POWER ASSIST VOLTAGE:	12-14/24-28/28-30 VOLTS
POWER CABLE LENGTH:	14 FT, ADAPTERS INCLUDED
BUILT-IN AUTOMATIC CHARGER:	120/208/220 VOLT AC, 20 AMP, 50/60HZ

CAPACITY

EMPTY SPEED:	8 MPH
FULL LOAD SPEED:	3 MPH
MOTOR HORSEPOWER:	6 HP
MOTOR DUTY CYCLE:	CONTINUOUS

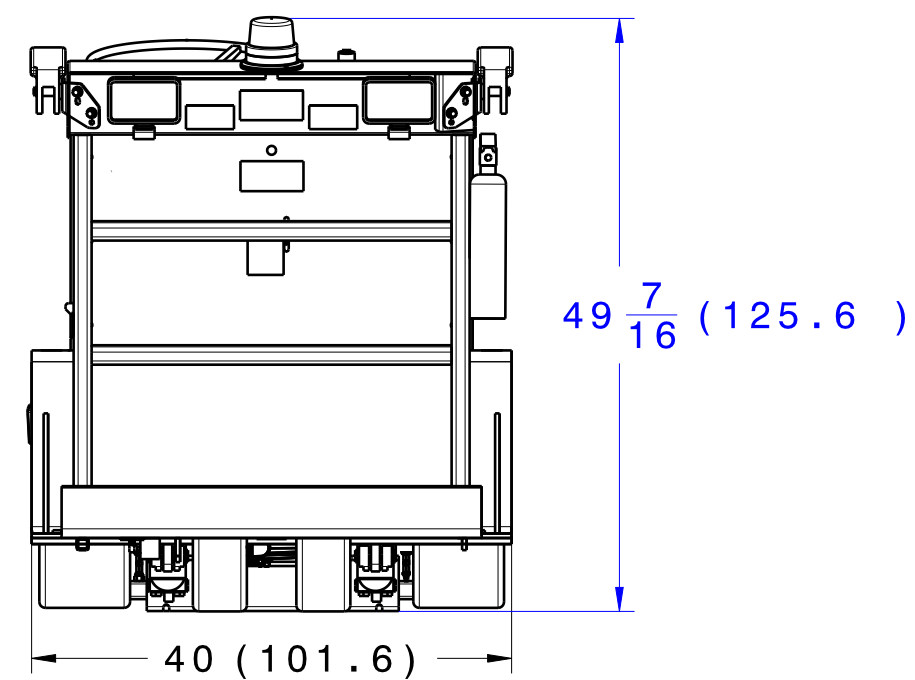

REAR VIEW

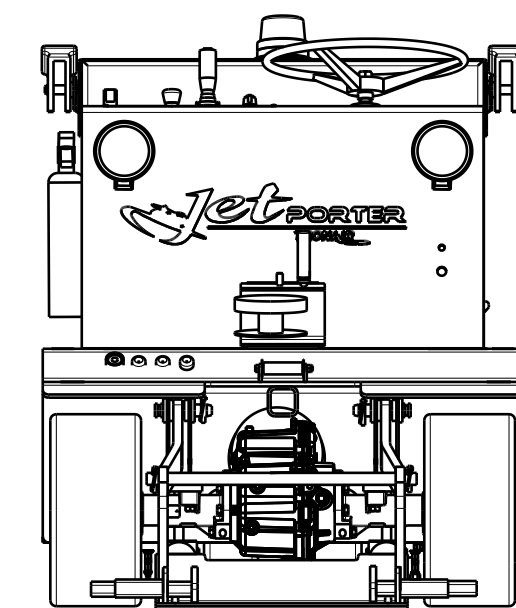

FRONT VIEW

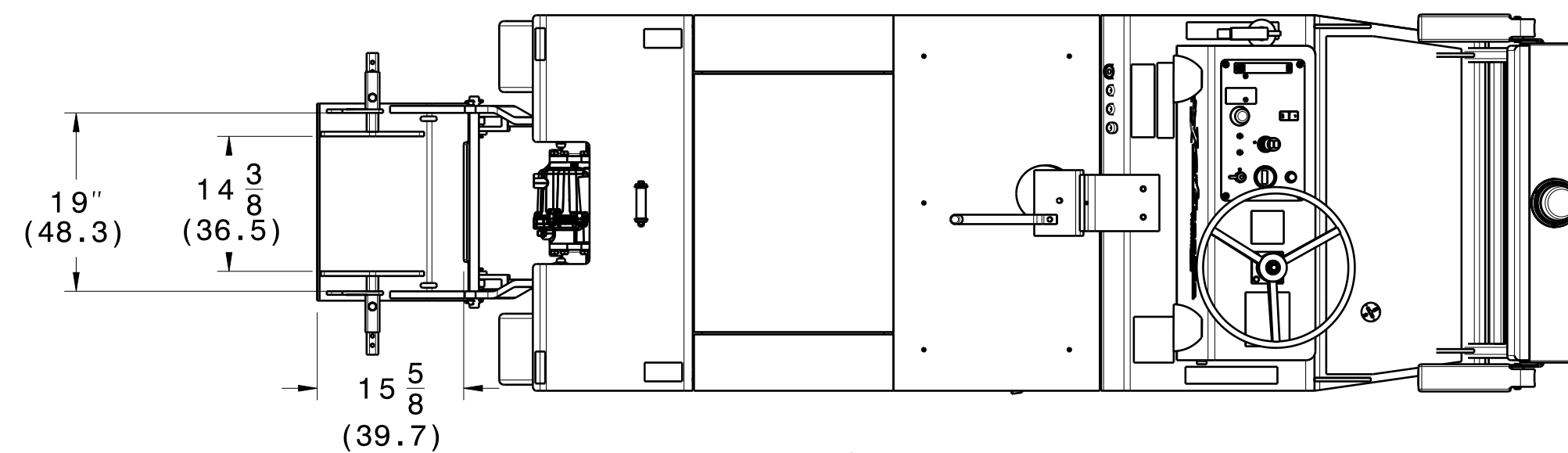

TOP VIEW

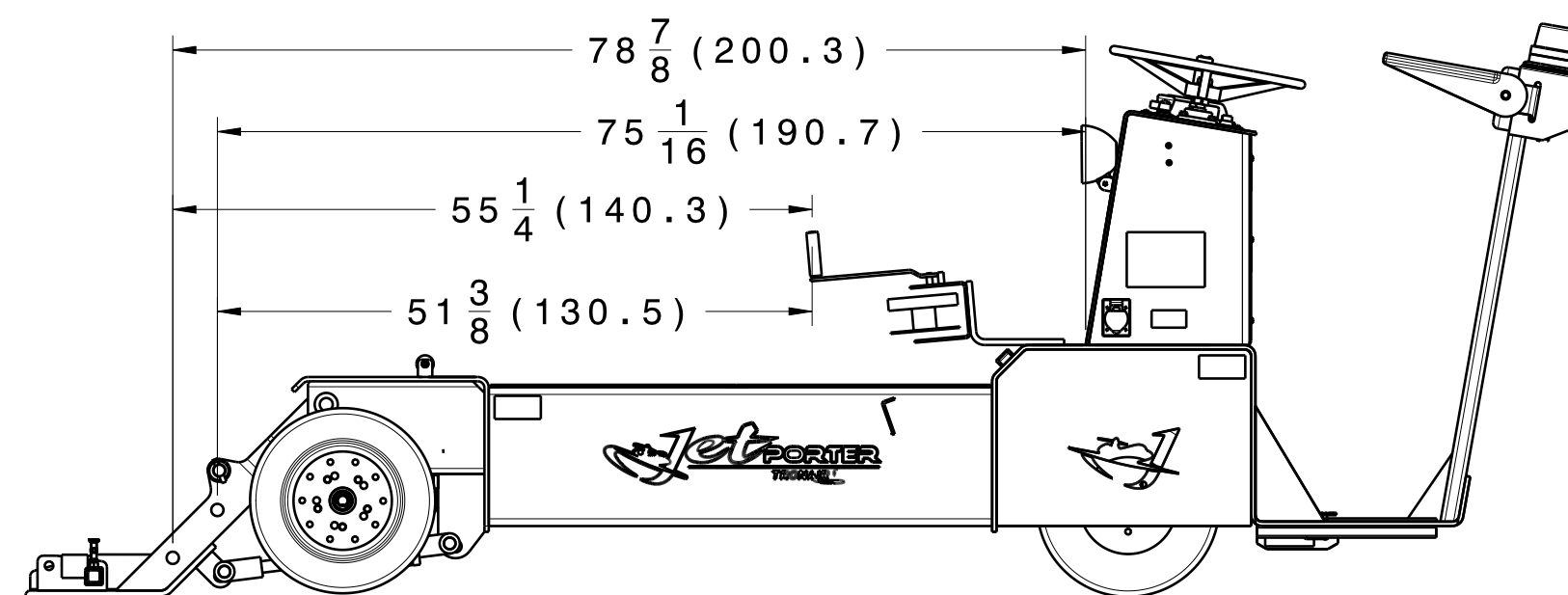

LEFT SIDE VIEW

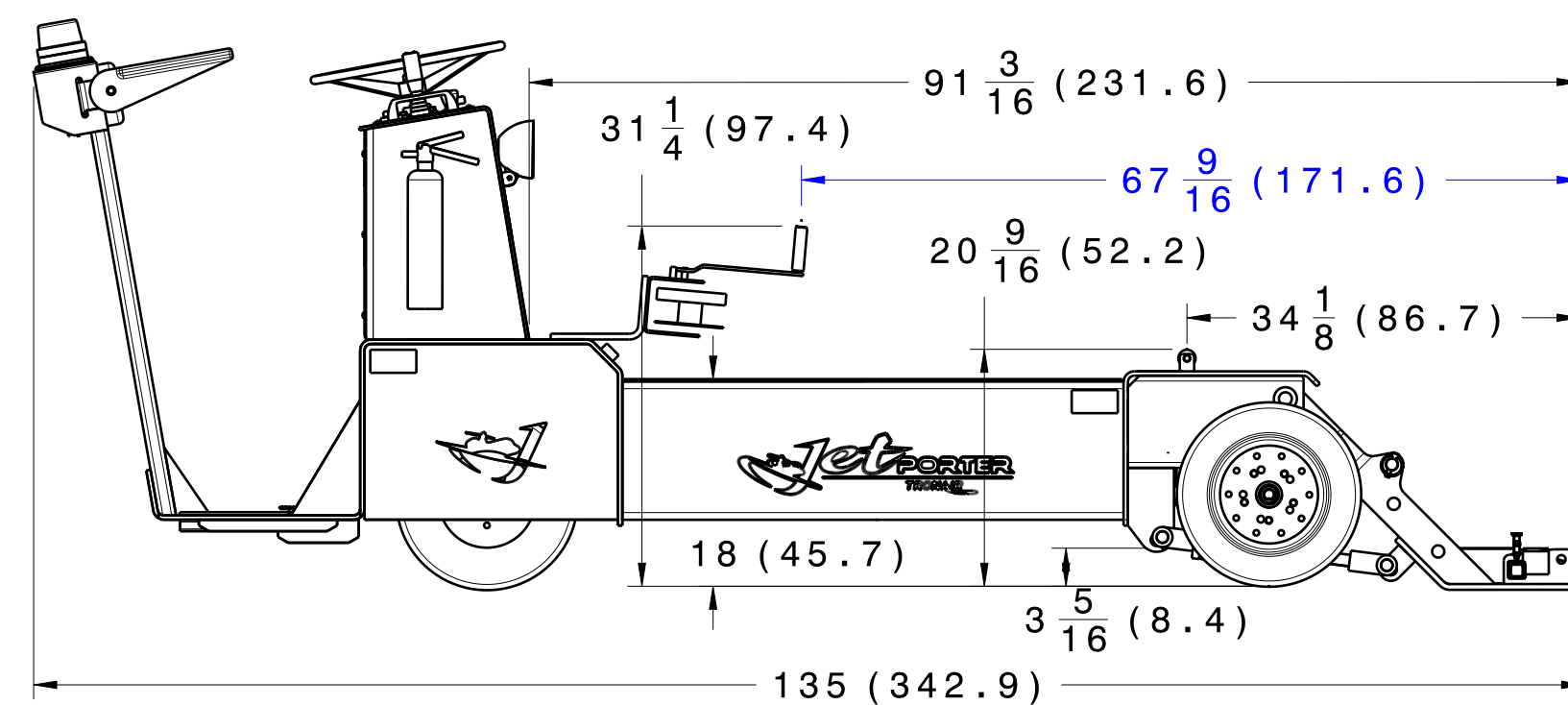

RIGHT SIDE VIEW

